



GrandVue

177, 643 and 143
Window Series



New Construction and Replacement Window & Door Systems



Slocomb Windows and Doors Knows Replacement and New Construction



When designing our windows and doors, our engineers and designers looked to the job-site for inspiration. They looked for solutions to everyday problems, simply stated, Slocomb solves problems.

As a second generation, family-owned business, our employees take personal pride in every window that comes out of our manufacturing facility. It is also why our products have been Energy Star® Certified, providing homeowners with the assurance of quality and performance.

Our plant and offices feature a state of the art facility that includes the most technologically advanced machinery, ensuring a quality finished product every time.

Each Slocomb window and door is individually custom made and inspected by our professionally trained quality control team. That's why the Slocomb window system is backed by one of the strongest warranties in the industry.

DESIGN FLEXIBILITY

We manufacture a compatible series of vinyl windows to meet virtually any design idea you may have. We can produce windows in a variety of styles, shapes, and sizes to replace those old drafty windows in your home.



ProTech 177 Replacement Windows Features and Benefits

When designing our vinyl replacement window system, we looked to nature for inspiration. The result was the ProTech 177; a vinyl window system designed for durability, strength, security and uncompromising beauty.

Heavy Walled Construction:

0.080" thickwalls

Deeply Pocketed Head:

With weatherstripping to resist air infiltration

7/8" Insulating Glass:

With optional Low 'E' coating specifically chosen for maximum regional thermal efficiency

Dual Tilt In Sashes:

Both sashes tilt in for easy cleaning

Die Cast Cam Lock and Keeper:

Cam action actually draws sash closer together for positive lock

Interlocking Meeting Rail:

Integral interlock provides additional security

Three Layers of Weather Stripping:

With double mylar fins for resistance to air and water infiltration

Optional Fiberglass Insulation:

In frame and sash to improve thermal performance

Flexible Bulb Seal:

Provides a superior high performance weather seal like are frigerator door

Fully Welded Double Wall

Interior Dam Leg:

With fin-seal weather-stripping for improved strength and optimal air and water performance.

Positive Sloped Sill:

Provides water runoff, even in driving rain



Fusion Welded Frame and Sash:

The utmost in strength and integrity

Warm Edge Technology:

Low conductivity spacer provides barrier to heat transfer in insulating glass unit

Night Vent Latch:

Allows for ventilation with security.

Low Profile Routed-in Tilt Latches:

Color matched low profile latches for a neat appearance

Innergy™ Rigid Thermal Reinforcement:

Innovative, superior, energy-efficient alternative to aluminum reinforcement

Stainless Steel Constant Force

Balance: Trouble free, maintenance free Provides smooth operation

Storm Interlock:

Integral sill and meeting rail lock and prevents sash from bowing under structural stress

Structural DP Rating of 50: up to 40 x 63 size window, call CSR to verify larger sizes.

Screen Options

- **Half screen is standard**
- **Optional Full Screen:** All full screens are FlexScreen technology a high performance spring steel frame that is captured in the screen track and can easily be removed from inside the home.
- **Limited Lifetime Warranty**



GrandVue 177 New Construction Windows Features and Benefits

GrandVue 177 windows are engineered specifically for new construction applications. We know and understand the needs of builders and architects who care about both performance and aesthetics. We sweat the details so you don't have to.

BUILT FOR A LIFETIME

GrandVue 177 windows are built to withstand the harsh weather conditions that come with the Northeast. We have combined the finest in window technology to bring you a structural system that will provide optimum performance and fine sight lines that will deliver enduring beauty.

DESIGN FLEXIBILITY

In addition to our GrandVue 177 double hung new construction window, we manufacture a compatible series of new construction vinyl windows to meet virtually any design dream you may have. When designing our windows, we looked for solutions to everyday problems, like unforgiving rough openings. Simply stated, Slocomb Windows and Doors solves problems.

Features

- Solid virgin PVC construction
- Exterior glazing bead around the glass
- High tech fusion-welded frame and sash
- 7/8" insulated glass
- Heavy duty sash locking system
- Full 3 1/4" frame depth
- Extruded 1 3/4" Nailing Fin

Options

- Available in sculpted or flat, designer, diamond, or prairie grid configurations. Simulated grids also available
- Optional Low E glass and Argon gas
- Optional tempered glass
- Optional obscure glass (frosted)
- Optional 4 9/16" or 6 9/16" primed finger joined pine extension jambs
- Optional drywall receiver
- Optional 3/4" extension jamb receiver
- Optional exterior New England flat picture frame or sill nose casing

Benefits

- Never needs painting
- Smooth interior finish
- Easy cleaning and maintenance from inside the home with tilt in sash on double hung model
- Fully weather resistant to wind and water
- Maximum energy efficiency
- Custom retrofit application
- Fully weatherstripped to eliminate drafts
- Limited lifetime warranty



Optional Factory Applied Drywall Return



Optional Factory Applied 4 9/16" or 6 9/16" Primed Pine Extension Jamb



Full 1 3/4" Nail Fin and Optional Integral "J" Channel



Solstice 643 Series Window Features and Benefits

Deeply Pocketed Head:

With weatherstripping to resist air infiltration

Fusion Welded Frame and Sash:

The utmost in strength and integrity

Dual Tilt In Sashes:

Both sashes tilt in for easy cleaning

Night Vent Latch:

Allows for ventilation with security

Interlocking Meeting Rail:

Integral interlock provides additional security

Equal Lite Sashes:

Same size glass on both sashes creates look of wood

Innergy™ Rigid Thermal Reinforcement:

Innovative, superior, energy-efficient alternative to aluminum reinforcement

Stainless Steel Constant Force Balance:

Trouble free, maintenance free. Provides smooth operation

Two Layers of Weather Stripping:

Each with double mylar fins for resistance to air and water infiltration

Warm Edge Technology:

Low-Conductivity spacer provides barrier to heat transfer in insulating Glass unit

Heavy Duty Die Cast Locks:

Securely attached to both vinyl sash and reinforcement.

3/4" Insulating Glass:

Standard LowE glass, using a high tech coating specifically chosen for maximum regional thermal efficiency

Positive Sloped Sill:

Provides water runoff, even in driving rain

Fiberglass Insulation: In frame and sash for maximum energy savings and efficiency

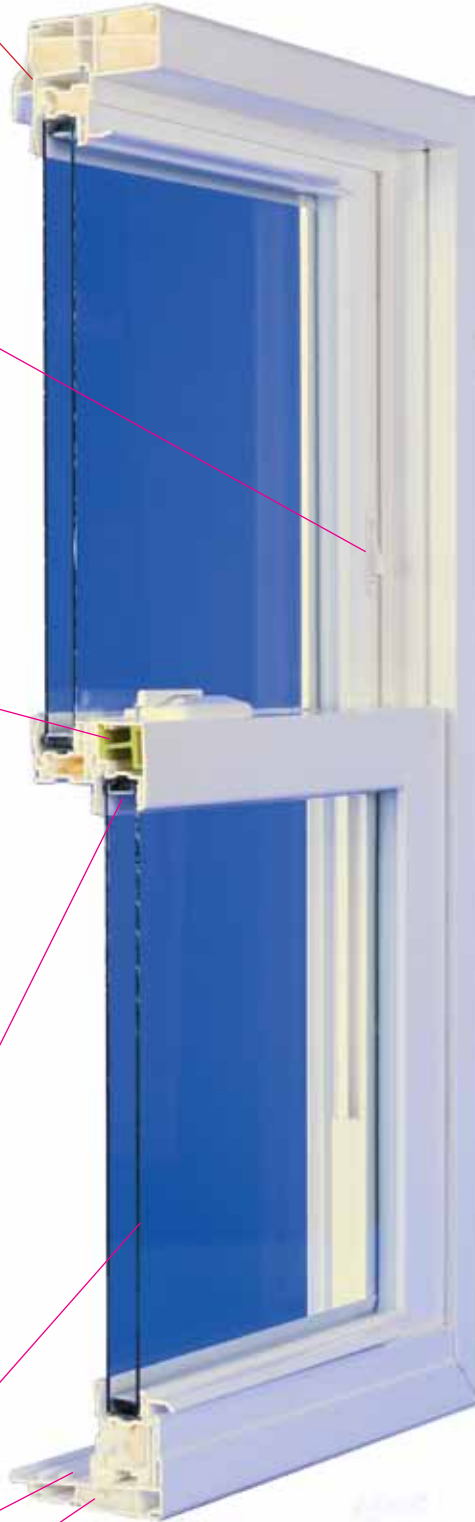

Optional Features



- **Optional Dual Tech Lock System:** The lock activates the tilt latch and is hidden from the outside of the home.

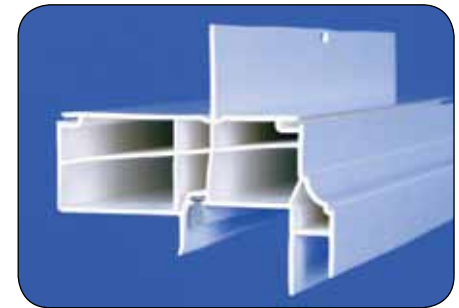

- **Extruded 1^{3/4}" Nailing Fin:** Provides easier and more error proof installation
- **Steel Reinforcement in meeting rails. In all rail widths**
- **Structural DP Rating of 50:** up to 40 x 63 size window, call CSR to verify larger sizes.

Screen Options

- **Half screen is standard**
- **Optional Full Screen:** All full screens are FlexScreen technology a high performance spring steel frame that is captured in the screen track and can easily be removed from inside the home.
- **Limited Lifetime Warranty**



Harmony 143 Series Window Features and Benefits

- **Fusion Welded Frame and Sash:** Provides an impenetrable barrier to air and water penetration and the utmost in strength and integrity.
- **Deeply Pocketed Head:** With weather stripping to resist air infiltration. For increased strength and stability.
- **Unique Cove Mold Look:** Offers a more traditional wood window exterior appearance.
- **3/4" Insulating Glass system:** For maximum regional thermal efficiency. Optional Low-E coating or Low-E with Argon for additional energy savings.
- **Warm Edge Technology:** Non-Conductive spacer provides barrier to heat transfer in insulating glass unit.
- **Recessed-in Tilt Latches:** Color matched low profile latches for a neat appearance.
- **Constant Force Balance System:** Provides smooth and maintenance free operation of sash.
- **New soft curved sash design:** Looks more like traditional wood window sash.
- **Attractive Integral Lift rail:** Provides easy sash operation.
- **Dual Tilt In Sashes:** Both sashes tilt in for easy cleaning.
- **5° Positive Sloped Sill:** Provides water runoff, even in driving rain.
- **Sunshield® Vinyl:** An advanced vinyl window material with a proven weather beating formula.



- **Interlocking Meeting Rail:** Integral interlock provides additional security and has passed AAMA Forced Entry Resistance Test*.
- **Die Cast Cam Lock and Keeper:** Cam action actually draws sash closer together for positive lock.
- **Double Night Vent Latches:** Allow for ventilation with security. Have passed AAMA Forced Entry Resistance Testing*.
- **Two Layers of Weather Stripping:** With double mylar fins for resistance to air and water infiltration.
- **Non-Corrosive Hardware:** Years of trouble free performance, no matter what the environment.
- **Available in a variety of window configurations and styles:** Including Single Hung, Double Hung, Picture Window and Slider
- **Optional Extruded 1 3/4" Nailing Fin for New Construction Applications:** Provides easier and more error proof installation



- **Limited Lifetime Warranty**
- **Half screen is standard**
- **Optional Flexscreen Technology Full Screen**



Color Options for 143, 643 & 177 Series

143, 643 and 177: Standard solid color Creme White or Optional Desert Tan.

643 and 177: Optional Bronze or Black laminated exterior over Creme White interior.

143, 643 and 177: We also offer 10 optional exterior paint colors plus custom colors from customer chips on all systems. *Customer must sign off on all custom colors.

177: Optional Natural Oak or Cherry interior Wood Grain with Creme White or Desert Tan exterior.



White PVC
(Standard)
143,643 & 177



Desert Tan PVC
(Optional)
143,643 & 177

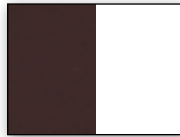

Bronze Exterior
White Interior
(Optional) 643 & 177

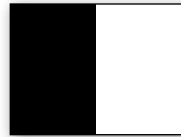

Black Exterior
White Interior
(Optional) 643 & 177



Oak Wood Grain*
(Optional) 177



Cherry Wood Grain*
(Optional) 177

* Wood grain not available on jamb extensions

143, 643 & 177 Screen Options

- **Optional Full Screen:**
All full screens are FlexScreen technology a high performance spring steel frame that is captured in the screen track and can easily be removed from inside the home.
- **Half screen is standard**



143, 643 & 177 Grid Options

Optional Sculpted, Flat Grids or Simulated Divide Lite (SDL) Grids



143, 643 and 177



143, 643 and 177



177 Only

Window Configurations

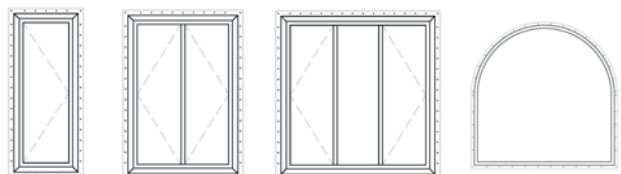
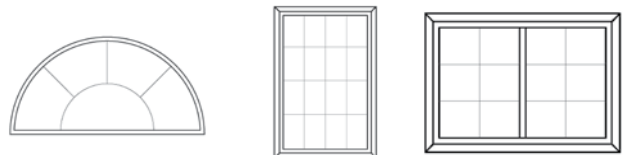
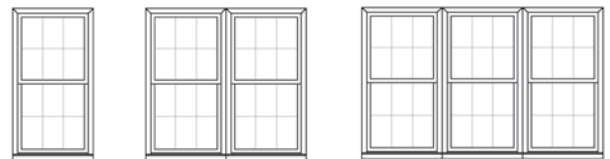

Optional Blinds Between The Glass

Available in select windows and patio doors
* Up to 36" wide on windows



143, 643 and 177 Slider and Picture Windows



Features

- Solid virgin PVC construction
- High tech fusion-welded frame and sash/vent
- 3 ¼" frame depth
- Interior scalloped glazing bead
- 3/4" insulated glass -143 and 643 systems
- 7/8" insulated glass -177 system
- For New Construction and Replacement applications
- Extruded aluminum screens

Options

- Available in a variety of optional colors
- Available in sculpted or colonial, designer, diamond, or prairie grid configurations. Simulated grids also available
- Optional Low E glass and Argon gas
- Optional tempered glass
- Optional obscure glass (frosted)

Benefits

- Never needs painting
- Smooth interior finish
- Fully weather resistant to wind and water
- Maximum energy efficiency
- Custom retrofit application
- Fully weatherstripped to eliminate drafts
- Limited lifetime warranty

143, 643 and 177 Slider and Picture Windows

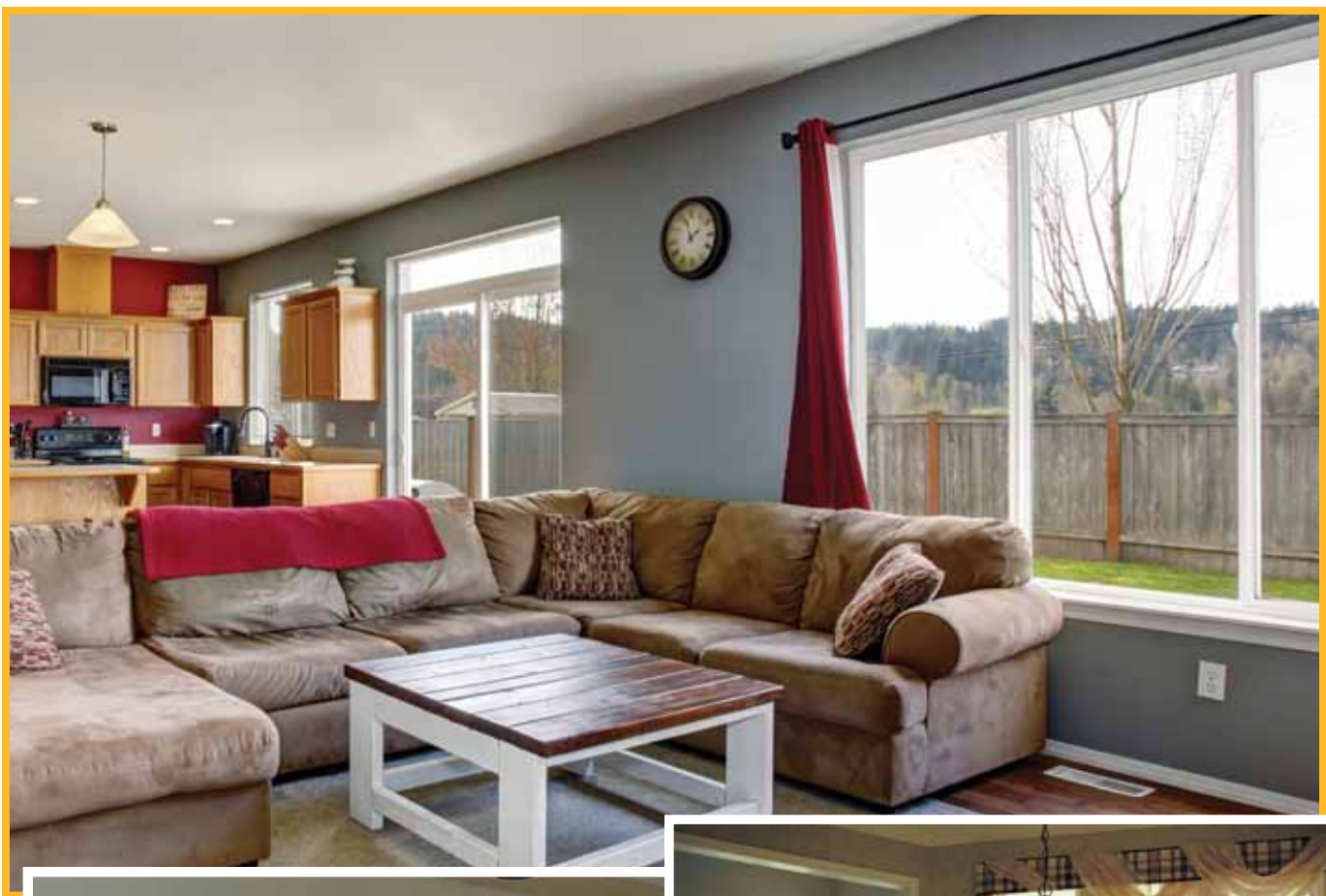

2 Lite & 3 Lite Sliders

- Sashes lift out for easy cleaning. But for added security, only lift out from the inside.
- Heavy duty tandem brass rollers allow for easy operation.
- Independent weep holes for excellent drainage.
- Sashes have equal-size glass for an appealing appearance. (2 lite only)

143, 643 and 177 Casement, Awning and Hopper Windows



Features

- Solid virgin PVC construction
- High tech fusion-welded frame and sash/vent
- 3 ¼" frame depth
- Interior scalloped glazing bead
- 3/4" insulated glass -143 and 643 systems
- 7/8" insulated glass -177 system
- For New Construction and Replacement applications
- Extruded aluminum screens

Benefits

- Never needs painting
- Smooth interior finish
- Fully weather resistant to wind and water
- Maximum energy efficiency
- Custom retrofit application
- Fully weatherstripped to eliminate drafts
- Limited lifetime warranty

Options

- Available in a variety of optional colors
- Available in sculpted or colonial, designer, diamond, or prairie grid configurations. Simulated grids also available
- Optional Low E glass and Argon gas
- Optional tempered glass
- Optional obscure glass (frosted)



Casement Options

- Standard multi-point self-locking system
- Simulated Decralite® double hung meeting rail

CONFIGURATIONS

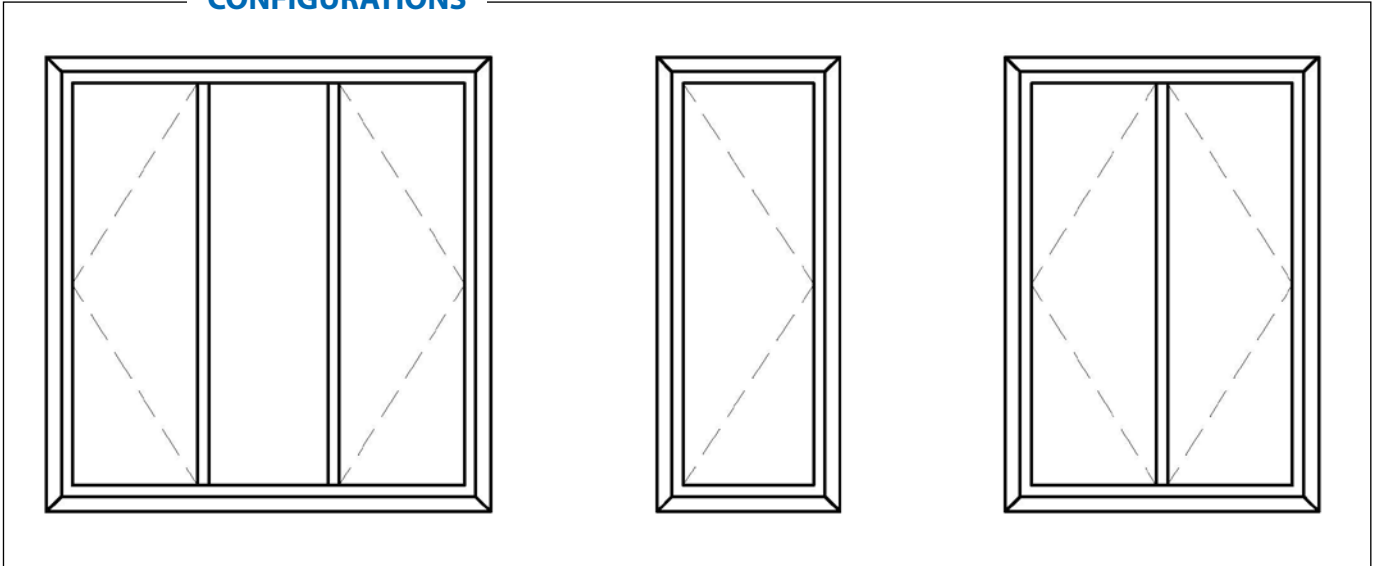

Awning and Hopper Options

- Awning center crank operator with scissor arms
- Awning side locking handles
- Hopper top sash/vent cam lock handle
- Hopper sash/vent hinges



CONFIGURATIONS

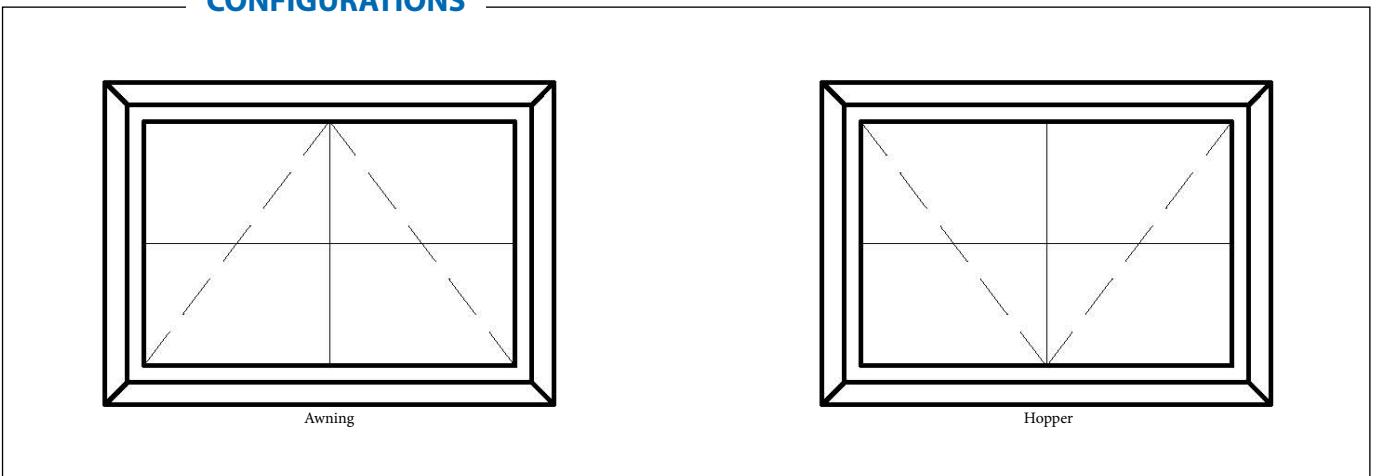

Bay and Bow Windows

Windows are an important component of any home – bringing in natural light, affecting the home’s overall look, and framing the world outside. Our bay and bow windows are made with skilled craftsmanship and from high quality materials. Each is structurally sound and mulled together with solid wood mullions. The interior showcases real wood trim around each individual window, as opposed to the commercial solid white look of vinyl mulled units.



Features

- Bay/bow windows are built to custom opening sizes.
- Frames can be built to accommodate any wall thickness.
- Many different insert window (sash) combinations are available.
- All normal replacement window options are available for the insert windows (sash).
- A variety of projection angles:
 - 15°, 30°, or 45° Bay Window Styles
 - 10° and 15° Bow Window Styles with your choice of three, four or five lites
- Custom styles, on any half degree, are also available

Benefits

- Maximum energy efficiency
- Excellent thermal performance and reduces outside noise
- Long lasting weather-tight performance

Options

- Custom finish options available, including laminate and oak
- Interior laminate, recessed lighting, and roof options available
- Can be combined with any Slocomb double hung, slider, or fixed picture window and/or operable casement or fixed picture window
- Available in a variety of optional colors

Bay Bow Options



Real Wood Interior Trim

The interior of your new bay/bow window will be trimmed with solid Oak. Real wood interior trim adds warmth and craftsmanship to these showcase windows. The molded trim breaks up an otherwise flat and bland appearance making the bay or bow feel like it is a part of the room and not just an after-thought.

Finished Interiors

Factory-finished interiors can save you time, money and the potential for costly mistakes. During the factory pre-finishing we are able to individually finish each component in a clean humidity controlled environment and then assemble your unit.

Garden Windows



Features

- High tech fusion-welded frame and sash
- Trim profile design
- Multi-point self-locking system
- Heavy duty weather stripping

Benefits

- Fully weather resistant to wind and water
- Maximizes the glass area for a clear, brighter view
- Weather-tight performance
- Resists the most inclement weather

Garden Window Options

- Available in a variety of optional colors
- Optional Low E glass and Argon gas
- Optional tempered glass
- Optional ¼" tempered glass shelf
- Optional fully operating self-locking trapezoid side sash/vents with extruded aluminum screens

Slocomb Patio Doors

Slocomb patio doors offer a contemporary touch to your home while providing quality that can withstand the Northeast weather.



Options

- Optional Low E glass and Argon gas
- Optional aluminum sill cover
- Optional foot lock
- Tempered high performance Low-E
- Stainless steel rollers
- Brass coated locking handle
- Blinds Between Glass (5, 6 and 9')
- Multi-point locking system
- Florida Approved DP50 Sliding Glass Patio door available.

Features

- High tech fusion-welded frame and panels
- Integrated transoms and side lites
- Sizes up to 16' wide and/or 8' high

Benefits

- Fully weather resistant
- Eliminates air and water infiltration

True 3 and 4 Panel Doors

- Standard widths are 5', 6', 8', 9' (3 panel)
- 12' (3 and 4 panel) and 16' (4 panel)
- Standard height is 79.5"

Patio Door Grid Options

Optional Sculpted, Flat Grids or Simulated Divide Lite (SDL) Grids



Patio Door Color Options

Standard solid color Creme White or Optional Desert Tan; Natural Oak or Cherry interior Wood Grain with Creme White or Desert Tan exterior; Bronze or Black laminated exterior over Creme White interior. We also offer 10 standard exterior paint colors plus custom colors from customer chips on all systems.*

* Customer must sign off on all custom colors.

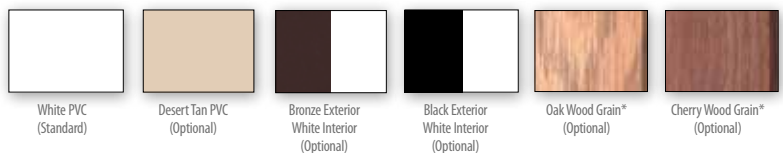

* Wood grain not available on jamb extensions

CONFIGURATIONS

	5'	6'	8'	9'	9' & 12'	10', 12' & 16'
Sliding Door	59 1/2" x 79 1/2" 58 1/2" x 81"	71 1/2" x 79 1/2" 70 1/2" x 81"	95 1/2" x 79 1/2" 94 1/2" x 81"	107" x 79 1/2" 143" x 79 1/2" 105 1/2" x 81" 141 1/2" x 81"	107 1/2" x 79 1/2" 143 1/2" x 79 1/2" 106" x 81" 142" x 81"	116 1/2" x 79 1/2" 140 5/8" x 79 1/2" 114 5/8" x 81" 138 9/16" x 81"

State of the art in Performance Technologies

Be Comfortable With Your Energy Bill

The high energy performance of the Slocomb windows have the combined factors of a Warm Edge spacer and High Performance Low-E glass. Combine these technologies with an Argon gas fill and you will maximize your energy performance and decrease your heating and cooling costs. In the winter months, Low-E helps keep heated air inside and cold air outside. In the summer, Low-E helps keep cool air in and hot air out. Low-E also blocks up to 84% of the harmful ultraviolet rays which can fade carpets, draperies and artwork. In addition since Argon gas is six times more dense than air, it greatly reduces the transfer of hot and cold-adding even more thermal efficiency. It is this combination of Warm Edge and Low-E/Argon filled glass that helps you save on your heating and cooling costs.

ENERGY STAR® PERFORMANCE CHARTS

Superior Energy Savings Performance with two Low E Glass Packages*

177 Window Systems

643 Window Systems

143 Window Systems

<p>Low-E² Glass</p> <p>U-Factor .26</p> <p>Solar Heat Gain Coefficient .25</p> <p>Visible Transmittance .46</p> <p>Air Leakage < 0.3</p>	<p>Low-E² Glass</p> <p>U-Factor .26</p> <p>Solar Heat Gain Coefficient .28</p> <p>Visible Transmittance .51</p> <p>Air Leakage < 0.3</p>	<p>Low-E² Glass</p> <p>U-Factor .27</p> <p>Solar Heat Gain Coefficient .26</p> <p>Visible Transmittance .47</p> <p>Air Leakage < 0.3</p>
<p>Low-E³ Glass</p> <p>U-Factor .26</p> <p>Solar Heat Gain Coefficient .19</p> <p>Visible Transmittance .44</p> <p>Air Leakage < 0.3</p>	<p>Low-E³ Glass</p> <p>U-Factor .26</p> <p>Solar Heat Gain Coefficient .21</p> <p>Visible Transmittance .49</p> <p>Air Leakage < 0.3</p>	<p>Low-E³ Glass</p> <p>U-Factor .27</p> <p>Solar Heat Gain Coefficient .21</p> <p>Visible Transmittance .50</p> <p>Air Leakage < 0.3</p>



U = U-Value R = R-Value
(SHGC) = Solar Heat Gain Coefficient
(VT) = Visible Transmittance

NOTE: "LE" Low "E" coating is on the number "2" glass surface when viewed from the exterior. U-values noted above are reflective of either PPG Solarban 70XL® or AGC Low "E" glass.

* "U" Value and "R" Value in accordance with NFRC 100-2010: Procedure for determining fenestration product U-factors.

** Solar Heat Gain Coefficient and Visible Transmittance in accordance with NFRC 200-2010: Procedure for determining fenestration product Solar Heat Gain Coefficient and Visible Transmittance at normal incidence.

*** Condensation Resistance Factor in accordance with NFRC 500-2010: Procedure for determining fenestration product condensation

Glass shall be set with neoprene glazing blocks to maintain uniformity around the glass perimeter. Standard glazing shall be nominal 7/8" thick sealed insulating glass consisting of two pieces of SSB clear float glass (double glazed). Optional glazing shall be nominal 7/8" thick sealed insulating glass consisting of one piece of SSB clear float glass and one piece of SSB low "E" glass. Argon Gas fill is standard with low "E" glass. All insulating glass units come standard with Quanex Duralite® warm edge IG spacer.

UltraFlect... the top performing dual Low-E glass option

Unlike traditional LowE glass, that has 1 coating on 1 glass surface, UltraFlect uses an unparalleled combination of 2 different High Tech reflective coatings with one coating on each piece of glass. UltraFlect represents the most dramatic advance in window glass technology in more than 10 years. Only UltraFlect breakthrough technology provides the R-5 performance of triple pane glass with the durability and appearance of dual pane glass.

UltraFlect Achieving An R-Value of 5.00

Only UltraFlect combines proven technologies in high tech glass coatings, spacer systems, and gas filling to produce the most thermally efficient heat reflective and durable insulated glass package:

3 layers of Silver Oxide (11 total layers) Protected inside the dry air space. Specially formulated and positioned to best reflect suns rays outside.

1 ceramic layer of Tin Oxide permanently bonded into the glass surface. Specially formulated and positioned to best reflect heat energy from your furnace inside.

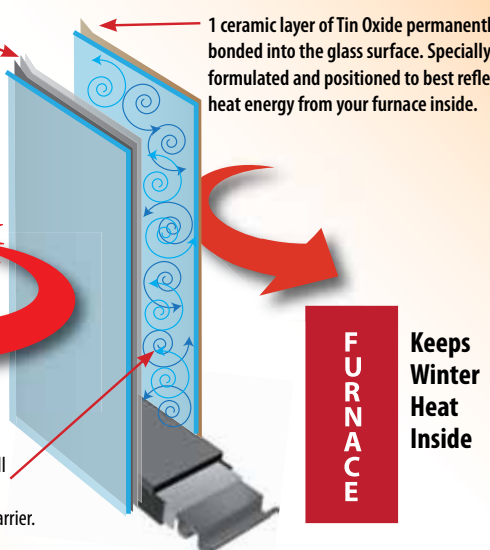

Keeps Summer Heat Outside

Argon Gas fill provides an insulation barrier.

FURNACE

Keeps Winter Heat Inside

Duralite® warm edge spacer system seals glass unit and insulates the edge.

Independent Laboratory Test Results

177 Window Series

U-Factor

.22

Solar Heat Gain Coefficient

.18

Visible Transmittance

.41

Air Leakage

< 0.3

643 Window Series

U-Factor

.22

Solar Heat Gain Coefficient

.18

Visible Transmittance

.41

Air Leakage

< 0.3

Optional UltraFlect exceeds all ENERGY STAR qualifications, including the newstandards that went into effect January 2010, and is eligible for a federal tax credit under Section 25C



WARNING: ASK TO SEE THE NFRC RATINGSTICKER, and COMPARE.* Optional

Comfort

Choosing windows for your home requires consideration of the light and ventilation desired; both the interior and exterior appearance; the ease with which you can maintain, clean and use everyday; plus their energy performance and sound protection. Slocomb Window and Door Systems can satisfy all of these requirements but, most of all our windows are designed and built to enhance the comfort and value that you associate with your home.

Value

Slocomb Window and Door Systems represents state of the art design in window systems, among the most advanced in the industry. We offer styles and options to fit any architectural requirements – both contemporary and classic. We build to a quality level achieved from years of experience and back it with our Lifetime Limited Warranty



A member of the Earthwise Group



Manufacturers of Quality Products

Slocomb Windows & Doors, Inc.

767 Sans Souci Parkway • Hanover TWP, PA 18706 • Phone: 570-825-3675

For a complete list of product lines, details, and options, visit our website - www.slocombwindows.com